

# Data Sheet

# Industrial Parquet



HØRNING industrial parquet is a simple, incredibly durable solution.

The flooring has no tongues/grooves, so can be sanded many times.

The variations in the many small blocks lends the flooring its distinctive 'colour interplay', also making the flooring ideal for places with a lot of toing and froing, because wear and tear is not so apparent.

# Industrial Parquet – Data Sheet

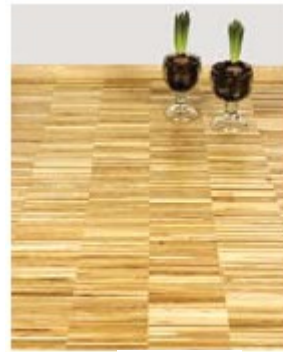
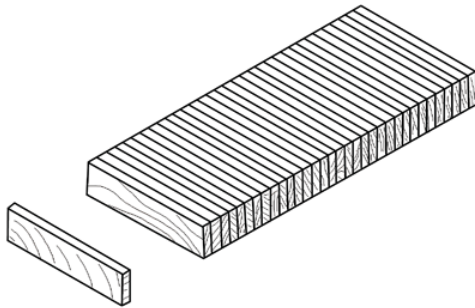

Ash

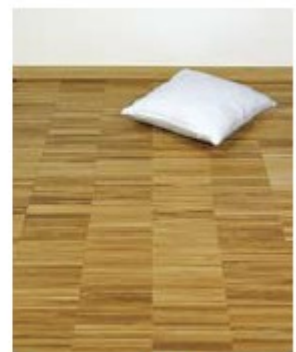

Oak

**HØRNING INDUSTRIAL PARQUET** are small solid wood blocks that are turned on end.

The blocks are put together in lengths of 320 mm, here the single blocks are held together with thread or tape for a quicker installation. Other dimensions than above may occur.

**HØRNING INDUSTRIAL PARQUET** is very robust and especially suitable for areas with high traffic. Re-sanding the floor may be done many times since the material lacks tongue and groove.

**HØRNING INDUSTRIAL PARQUET** is less sensitive to moisture than other floors which makes it the perfect choice for areas with high traffic.

## Dimensions

Thickness: 10 / 16 / 23 mm  
 Width: 8 mm  
 Length: 160 mm

## Wood types

Oak and Ash. Other types of wood on request.

## Surface coating

Untreated

## Indoor climate

It is important that the surface temperature never exceeds 27 degrees!

The relative humidity in the air (R.H.) must always be between 35-65% before, during and after installation.

**Always study the installation guide from HØRNING prior to installation.**

## Grading:

### Ungraded:

Vibrant and natural unsorted variation, both regarding structure and colour of wood. Healthy knots, sapwood and brown heart is allowed.

Grading depends on dimension and wood type. Wood is a natural material, variation in regards to description of grading, photographs etc will always occur. Samples are only examples and may never show grading in a whole batch. Variations between samples and actual orders always occur. For reference photographs visit: [www.horningfloor.dk](http://www.horningfloor.dk).

## Environment

FSC-certified wood is delivered on request.

HØRNING cares about the environment and sustainable forestry.

Naturally HØRNING is FSC-certified

## CE-certification

HØRNING floors are generally CE certified in accordance with the EC declaration regarding wooden floors for indoor usage EN 14342.



The mark of  
responsible forestry